

# APPLICATION MATRIX

## CYCLONE SEPARATORS

INDUSTRY	APPLICATION
Boilers	Coal, Husk & Bagasse.
Sugar Industry	Sugar dust & Bagasse.
Cement Industry	Pre-collector for cement mill pneumatically conveyed cement dust.
Metal Fines	Aluminium dust, copper chips, induction furnace exhaust and other types of metallic dust.
Abrasive and Sand Application	Fluid bed dryer, foundry sand & sand blasting system.
Plastic Resins and Chemicals	PVC, foam rubber, etc.
Automobile & Its Ancillaries	Buffing and Polishing.
Wood-products	Saw dust and wood ash.
Fertiliser Industry	Dedusting, dryer and cooler.
Fabric, Lint Paper & Fibrous Material	Synthetic fibre, Fibreglass, Cotton / Wool / Polyester / Nylon, Paper fluff.
Agro Based / Flour / Rice / Pulses	Dust Aspiration.

## BAG FILTERS

INDUSTRY	APPLICATION
Steel	Furnace-Process, Material Handling, Boiler, Kiln, Reactor Exhaust, Coal Preparation, Injection Coke Oven
Cement	Clinker Cooler, Coal Mill, Cement Mill, Kiln, Reactor Exhaust, Transfer Point-Dedusting, Alkali Bypass, Material Handling
Power / Agro Based/Sugar/Rice/ Tobacco/Breweries & Distilleries Solvent Extraction/Edible Oil / Textiles/Soaps Detergents & Waxes/Paints & Dyes/Paper & Pulp	Boilers, Material Handling
INDUSTRY	APPLICATION
Dairy/Food Processing	Boilers, Dryers
Drugs & Pharmaceuticals	Boilers, Dryers, Material Handling
Tyres	Boilers, Banbury Mixers
Sponge Iron	Kiln, Reactor Exhaust, Material Handling
Non Ferrous Metallurgical	Ovens Smelter, Furnace, Material Handling
Wood	Dryers, Boilers and Material Handling

## SCRUBBERS & WET COLLECTORS

INDUSTRY	APPLICATION	INDUSTRY	APPLICATION
Metal Treatment Industry	Hot-dip Galvanizing Plants	Process Industry	Pipe pickling, Stainless Steel Pickling, Wire Pickling
Metal Finishing Industry	Electroplating, Anodizing	Auto and Auto Ancillary Units	Phosphating, Pickling, Electroplating, Welding Fumes
Canteens & Restaurants	Cooking Fumes	Chemical Industries	Removal of SO <sub>2</sub> Fumes, Methane Gas, etc.
Oil Refineries	Fluid catalytic cracking units(FCCU)	Paint Shops	Removal of Particulate Paint.

### RANGE OF PRODUCTS

• Axial Flow Fans • Centrifugal Blowers • Kitchen Scrubbers • Ventilation Units  
Air Cooling Units • Dust Collectors • Rotary Airlocks • Air Handling System Accessories

### RANGE OF SYSTEMS

• Pressurisation & Ventilation • Evaporative Air Cooling • Dust Extraction & Collection  
• Fume Extraction & Collection • Fresh Air Supply & Exhaust • Kitchen Ventilation  
• Pneumatic Conveying • Air Conditioning



**VENTECH SYSTEMS PVT. LTD.**

(An ISO 9001 : 2015 Certified Company)  
(Recipient of Bhartiya Udyog Ratna Award)  
(Authorized Channel Partners of Hitachi & LG)



**Corporate Office:** 511, Vikas Deep, Laxmi Nagar District Centre, Vikas Marg, New Delhi – 110 092 ( India )

**Phone:** + 91 – 11 – 22454054, 22454059 **Mobile:** + 91 97110 03363

**Telefax:** + 91 – 11 – 42448063 • **E-mail:** info@ventechsystems.com, sales@ventechsystems.com

**Branch Office:** 410, Angel Mega Mall, CK-1, Kaushambi, Ghaziabad

**Works:** Uttar Pradesh & Delhi

**Regional Representatives:** Lucknow, Raipur, Ahmedabad, Hyderabad, Karnal

**Overseas Representatives:** Canada, Singapore, South Africa



All Rights reserved. No part of this publication may be copied or published by means of printing, photocopying, microfilm or otherwise without prior written consent of Ventech Systems Pvt. Ltd. This restriction also applies to the corresponding drawings and diagrams.

In view of our constant endeavour to improve the quality of our products & systems, we reserve the right to alter the specifications without prior notice. We reserve the right to modify the specifications in accordance with improved designs. Although every effort will be made to maintain accuracy in the data given, the figures must be taken as approximate and in no way binding. Contact us for more information.

PULSE JET BAG FILTERS



CYCLONE SEPARATORS



# INDUSTRIAL AIR POLLUTION CONTROL DIVISION

ACID FUME SCRUBBERS

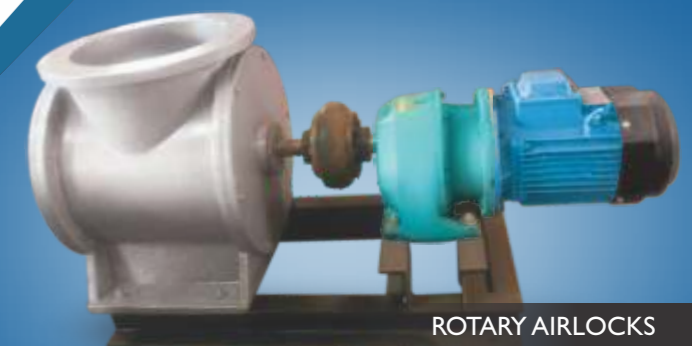

ROTARY AIRLOCKS

www.ventechsystems.com



# INTRODUCTION

Curbing Air Pollution in Industries is our business besides repertoire of HVAC products for various applications. We are one of the few companies to offer many emission control solutions for today's diverse Air quality needs. For past many years, VENTECH has offered State-of-the-Art Equipments and Systems to combat the ever increasing problem of Air Pollution.

VENTECH is your best choice for a full range of Industrial Air Pollution Control Systems from concept to commissioning. *We clean the Air for better returns.*

## CYCLONE SEPARATORS

Ventech High Dust Collection efficiency Cyclone Separators are Cost effective means for stringent particulate pollution control and material recovery. Cyclone Separator is used as a primary collector with or without bag filters, to separate dust of moderate to coarse particle size.

**SIZE RANGE:** 400 mm diameter to 2400 mm diameter.

**CAPACITY RANGE:** 1,000 CMH to 45,000 CMH.

### PRINCIPLE OF OPERATION

Cyclonic separation is a method of removing particulates from an air or gas stream, without the use of filters, through vortex separation. Rotational effects and gravity are used to separate mixtures of solids and fluids.

A high speed rotating (air)flow is established within a cylindrical or conical container called a cyclone. Dust laden air flows in a helical pattern, emanating at the top (wide end) of the cyclone and terminating at the bottom (narrow) end before leaving the cyclone in a straight stream through the center of the cyclone and out to the top. Larger (denser) particles in the rotating stream have too much inertia to follow the tight curve of the stream, and strike the outside wall, then falling to precision designed bottom hopper of the cyclone where they can be removed. In a conical system, as the rotating flow moves towards the narrow end of the cyclone, the rotational radius of the stream is reduced.

Depending on the application, Extraction Volume & desired Dust Collection efficiency, these sheet steel fabricated dust collectors are designed and manufactured in single, twin, or multiple stage configuration, in which a number of cyclones operate in parallel. Application requirements and site conditions are other important selection factors that influence the choice of an appropriate version.

Dust discharge is effected through a suitable dust discharge device like Rotary Airlock or Motorized Damper.

### SALIENT FEATURES

- Modular and sturdy construction ensuring ease of assembly at site.
- Can Handle upto 45,000 CMH (in single configuration)
- Can be manufactured in different Material of Construction like Mild Steel, Stainless Steel, MS with FRP Lining, etc. depending on the application.
- Surface treatment is done using epoxy and other anti-stick coatings which ensures dust does not stick inside the cyclone surface. Powder coating available on request.
- Available in Left and Right Hand Configuration to suit site layout.

### BENEFITS

- Low Initial Cost.
- Excellent pre-collector to Fine Dust collectors like Bag Filters, etc.
- Convenient and efficient cleaning of work area.
- Highly durable.
- No expensive filters involved, therefore ensuring ease of operation.
- Low maintenance costs.
- Works at high temperatures as well.

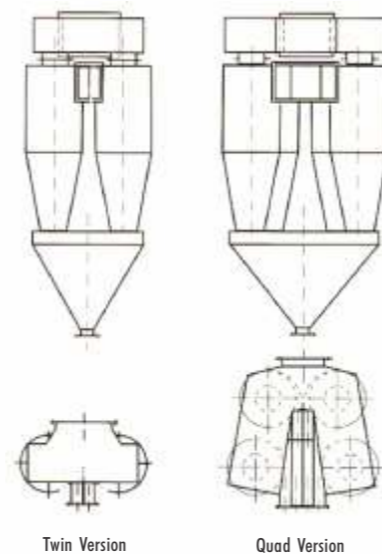
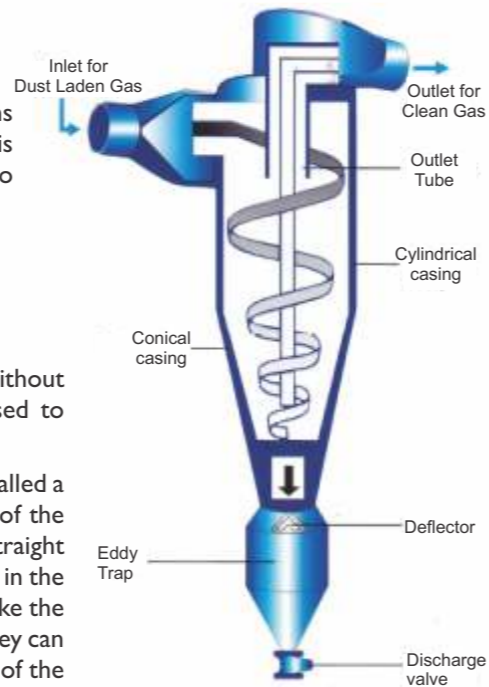

# PULSE JET BAG FILTERS

For particulate emission control, VENTECH Bag filters are setting industry standards.

Our wide assortment of Bag Filters offered in Rectangular and Cyclonic Configuration, economically meet the need of most industrial applications for collecting dust and controlling pollution of Air and form an integral part of Dust Extraction and Collection Systems. A high dust collection efficiency of approx. 99.997% ensures that they are widely used in most critical dust generation processes in the industry.

VENTECH pulse-jet system provides continuous, automatic online bag cleaning.

Capacity Range: 1 000 CMH to 3,50,000 CMH

### PRINCIPLE OF OPERATION

- Dust laden air enters the Dust collector through the hopper or casing depending upon application.
- An internal baffle distributes the dirty air within the housing. Dust laden air slows down as it enters the collector.
- Coarser dust particles drop into the hopper.
- The dirty air passes through the bags, dust is captured and collected on the bag exterior.
- On a timed cycle, a burst of compressed air is directed down through a venturi at the top of bag.
- Filtered clean air flows to the clean air chamber and exhausts through outlet.
- Periodic compressed air pulsation dislodges accumulated dust from the bags with cleaning frequency and duration adjusted by solid-state timers or PLC.
- Dust falls into the hopper for collection through the discharge device.
- Since the rows are sequentially cleaned one after another, there is no interruption of airflow through the filter. This provides a smooth operating dust control / material handling system.

## RECTANGULAR BAG FILTER

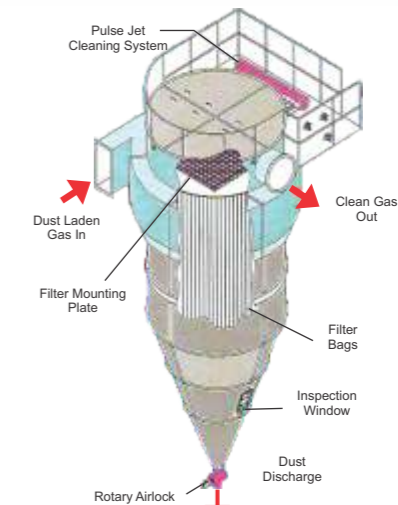
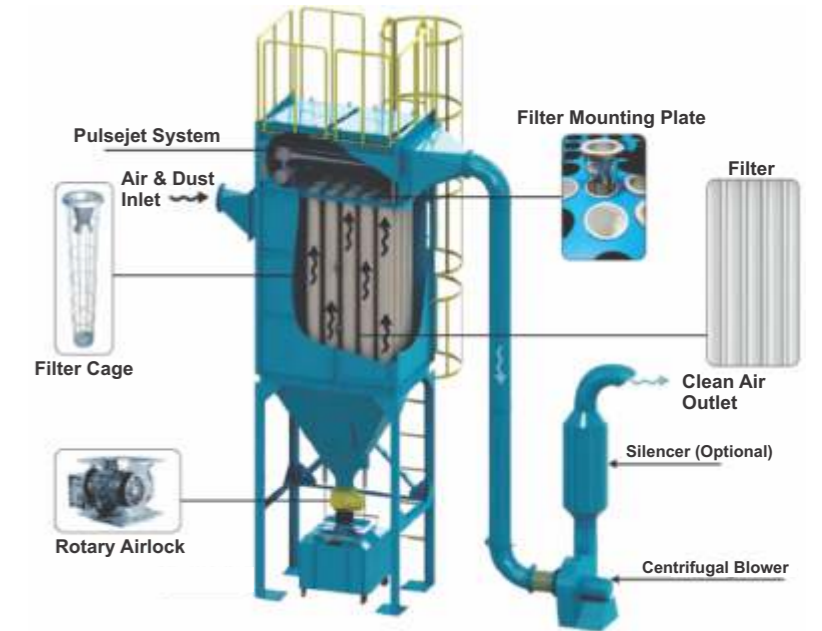

## CYCLONIC BAG FILTER

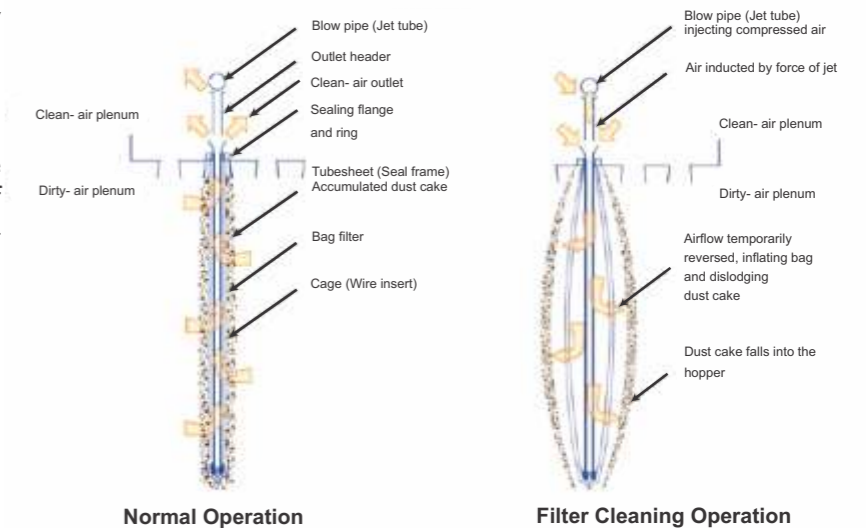

# PULSE JET BAG FILTERS

## SALIENT FEATURES

- Available in Rectangular / Square version for all types of industrial applications and also in Cyclonic version configuration especially developed for Rice / Flour Mills/Pulse mills.
- Removable top access panels.
- Top bag removal from clean air side.
- Durable construction of housing in modular form. Can be offered in variety of materials viz. Mild Steel, Stainless Steel, etc.
- Bags / Sleeves in variety of sizes and fabrics suitable to handle different materials.
- Heavy duty, smooth wire cages to support bags . Collapsible design also available.
- Flanges at inlet, outlet and dust particles discharge hopper.
- The commonly used filter media is non-woven synthetic and needle felt. Other wide variety of filter media are selected to suit different applications and characteristics of dust particles.



**DIFFERENTIAL PRESSURE GAUGE**



**SOLENOID PULSE VALVE**



**FILTER BAG & CAGES**



**SEQUENTIAL TIMER**



**FRL UNIT**

# FABRICS & TECHNICAL SPECIFICATION

## FABRICS

### TYPICAL CHARACTERISTICS

Fabric Type	Maximum Operating Temperature	RESISTANCE TO				
		Flex Abrasion	Moisture	Acid	Base	Organic
Polypropylene	90° C	Good	Excellent	Excellent	Excellent	Excellent
Acrylic	120° C	Good	Good	Good	Good	Good
Polyester	130° C	Excellent	Fair	Fair	Poor	Good
Nomex	190° C	Good	Poor	Poor	Fair	Good
Fiberglass	260° C	Poor	Excellent	Excellent	Excellent	Excellent
PPS	180° C	Good	Good	Good	Excellent	Good

## TECHNICAL DATA

Model	Power (kW)	Airflow (m <sup>3</sup> /h)	Filter Surface Area (m <sup>2</sup> )	Dimension L x B x H (m)	Filter Cleaning Mechanism	Location
VSBF-32-127-3.0	9.3	5000	38	1.6 x 0.8 x 5.5	Automatic Pulse Jet	Outdoor
VSBF-66-127-3.0	18.50	10000	79	2.2 x 1.2 x 6.1	Automatic Pulse Jet	Outdoor
VSBF-60-165-3.66	30.00	15000	114	2.25 x 1.35 x 6.1	Automatic Pulse Jet	Outdoor
VSBF-81-165-3.66	30.00	20000	154	2.025 x 2.025 x 6.8	Automatic Pulse Jet	Outdoor
VSBF-100-165-3.66	37.00	25000	190	2.25 x 2.25 x 6.8	Automatic Pulse Jet	Outdoor
VSBF-120-165-3.66	55.00	30000	228	2.295 x 2.25 x 7.5	Automatic Pulse Jet	Outdoor
VSBF-144-165-3.66	55.00	35000	273	2.7 x 2.7 x 7.5	Automatic Pulse Jet	Outdoor

- Note :**
- Bag house dust collectors are manufactured according to site specific requirement.
  - The table is indicative of few customized models.
  - Power Consumption may vary as per site layout. Aforesaid mentioned values are indicative only.



# ROTARY AIRLOCKS

Ventech has introduced a low cost solution to Dust Collector discharge valve needs. The dust discharge valve is a light duty option for standard dust collection applications.

We are engaged in manufacturing and supplying of wide range of Airlock Valves. These Airlocks are designed for use as an effective air lock system for constant material discharge and material metering.

Constructed with a robust cast iron body and cast iron end covers. Bearings are inboard and shafts are sealed with lip seals. All dust collector valves are direct driven with a right angle gearbox and motor.

These dust collector valves have been engineered and designed solely as a low cost alternative for applications with pressure differentials of 3 PSI or less.

## PRODUCT RANGE

Available in 150, 200, 250 and 300 mm round and square inlet sizes.

## SALIENT FEATURES

- ⊗ **Body:** Cast Iron precision bored (M.S. fabricated body is also available, on request).
- ⊗ **End Covers:** Cast Iron precision machined and Spigot Located into Valve Body.
- ⊗ **Rotor:** Fabricated Mild Steel Closed (Shrouded) Type Fully Machined.
- ⊗ **Bearings:** Ball Type Rigged Inboard Sealed for Life.
- ⊗ **Seal:** Shaft Seal Rubber Lip Type.
- ⊗ **Drive:** Rotor is mounted on shaft of Helical inline gear box assembled with standard TEFC flange mounted motor.
- ⊗ Consistent excellent performance, durability, efficiency and longer service life.
- ⊗ Rotor with Beveled Tips.
- ⊗ Rotor with Open / Closed Ended Construction.
- ⊗ Special Design for Granular Products.
- ⊗ Blow Through & Quick Cleaning Version Available.
- ⊗ Ambient Temperature: -25 to 100 Deg. C.
- ⊗ Heavy Duty Flanges.
- ⊗ The Rotary Airlocks supplied by us are complete with standard ABB / reputed make Motor, Heavy duty Gear Box, common base frame, coupling, Sight glass with tie rods and duly painted with anti-stick epoxy coating from inside.

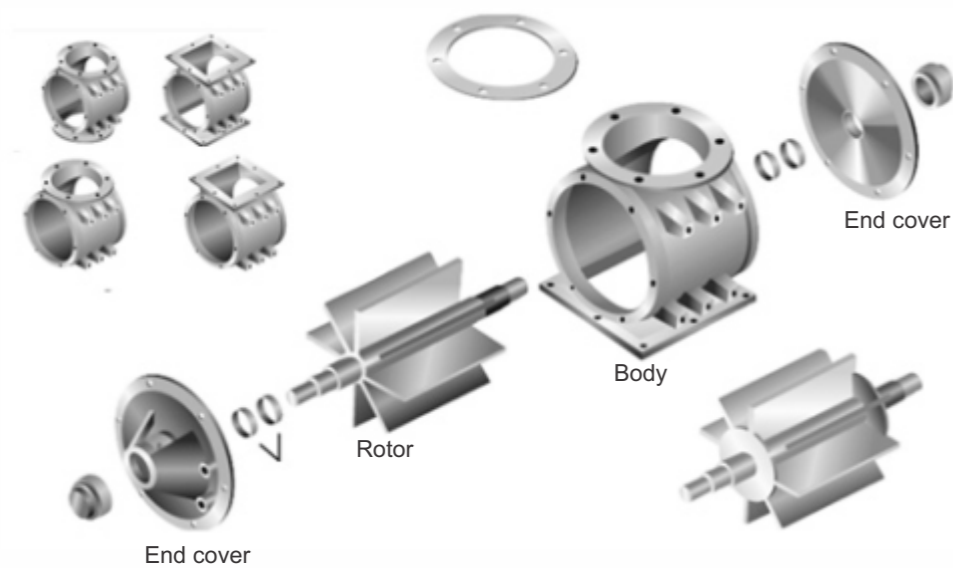

# WET SCRUBBERS

State-of-the-art technology acid fume (plate) scrubbers are offered, which are most effective equipments for scrubbing water soluble gaseous pollutants. Our wet scrubbers offer the latest technologies for acid gas control. Our Scrubbers are used for scrubbing hazardous gases like HCl, SO<sub>2</sub>, NH<sub>3</sub>, various noxious acid / alkali fumes etc. Number of installations for VOC (Volatile Organic Compound) control, solvent, and sulphur recovery and odour control have proven the economical, reliable performance of our fume extraction systems employing Scrubbers and services in the wide array of industries we serve.

**Size Range : 400 mm diameter to 3000 mm diameter in single stage.**

## TYPES OF WET SCRUBBERS

- Conventional Packed / Floating bed Scrubbers
- Spray Type Scrubbers.
- Impingement Plate Type Scrubbers.

### Principle of Operation

In this device, the foul gas is brought in contact with water or a suitable solvents to dissolve the contaminant and thus the gas stream is cleaned. The gases containing the fumes enter the scrubber from the bottom. It starts going up through the media chamber, due to the suction effect created by a blower.

The scrubbing liquid, generally water, flows down from the top, in the opposite direction. The water flowing down and the gases going up are thoroughly mixed in the packed bed section / media chamber, which generally contains raschig rings of suitable material that are randomly placed. These rings help in complete mixing of gases and the water by creating a larger surface area of contact and thus, more contact time. The quantity of packing material depends on the concentration of the gases. The scrubbing medium can be any fluid that will help in neutralizing the fumes. The cleaned gases escape from the top while the scrubbing fluid falls to bottom tank, re-circulated for scrubbing.

## SALIENT FEATURES

- ⊗ Wide range of Scrubber designs to cater to different types of particulate & gaseous pollutants.
- ⊗ The material of construction for the above types of scrubbers could be either metallic in mild steel, stainless steel or all synthetic (PP/PVC+FRP/FRV).
- ⊗ Compact and customised design.
- ⊗ High Scrubbing efficiency
- ⊗ All static construction, so easily maintainable.
- ⊗ Scrubbers are offered in Vertical as well as Horizontal versions to suit site conditions.
- ⊗ Simple & Reliable Operation.
- ⊗ Suitable for high or low concentration of pollutant.

## BENEFITS

- Increased productivity and safety.
- Environment friendly.
- Ensures hygienic working atmosphere.
- High separation efficiencies of particulate and gaseous emissions.
- Can be integrated in systems with upstream as well as downstream processes.

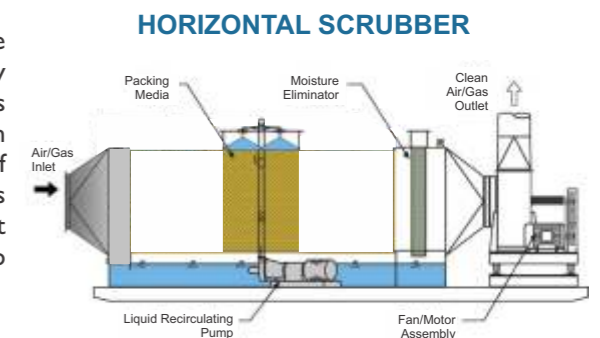
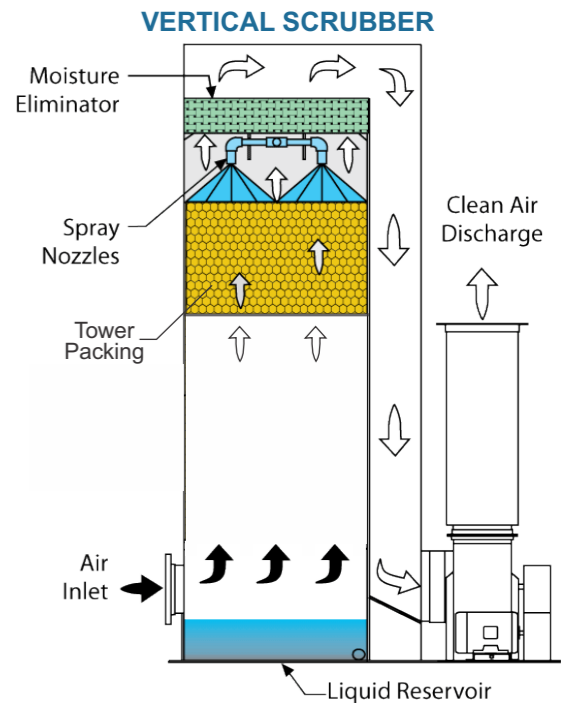

## IMPINGEMENT PLATE TYPE SCRUBBER

