

TECHNICAL DATA

Sr.No.	Model	Air Volume (CMH)	Air Volume (CFM)	Dimensions (MM)				Fan Motor (HP) @ 65 mm.wg. static pressure	Pump Rating (HP)	Sump Size with 4 bend PVC Eliminator			
				(Double Bank Spray) Length	(Single Bank Spray) Length	Width	Height			(Double Bank Spray) Width(W)	(Single Bank Spray) Width(W)	Length (L)	Height (H)
1	VSAS-3	5100	3000	3300	2700	1300	1300	3	1	1800	1200	1200	450
2	VSAS-4	6800	4000	3300	2700	1600	1300	5	1.5	1800	1200	1480	450
3	VSAS-5	8500	5000	3500	2900	1600	1600	5	1.5	1800	1200	1480	450
5	VSAS-7	11900	7000	3500	2900	1700	1600	5	2	1800	1200	1620	450
6	VSAS-8	13600	8000	3700	3100	1700	1900	7.5	2	1800	1200	1620	450
8	VSAS-10	17000	10000	3700	3100	1900	1900	7.5	3	1800	1200	1850	450
9	VSAS-12	20400	12000	3700	3100	2200	2400	10	3	1800	1200	2080	600
10	VSAS-15	25500	15000	4000	3400	2200	2400	10	3	1800	1200	2080	600
11	VSAS-18	30600	18000	4200	3600	2200	2600	12.5	5	1800	1200	2080	600
12	VSAS-20	34000	20000	4200	3600	2800	2600	15	5	1800	1200	2630	600
14	VSAS-25	42500	25000	4500	3900	2800	2600	20	5	1800	1200	2630	600
15	VSAS-28	47600	28000	4700	4100	3300	2600	20	5	1800	1200	3130	600
16	VSAS-30	51000	30000	4700	4100	3300	3000	20	5	1800	1200	3130	600
18	VSAS-40	68000	40000	5000	4400	3400	3400	30	7.5	1800	1200	3270	600
19	VSAS-45	76500	45000	5000	4400	4000	3400	30	10	1800	1200	3850	600
20	VSAS-50	85000	50000	5000	4400	4400	3400	40	10	1800	1200	4300	600

Note: ⚙️ Dimensions are indicative only. ⚙️ All dimensions are with standard 25 mm thick panels. ⚙️ Total Height(H) includes sump height. ⚙️ Unit base channel height is extra.

RANGE OF PRODUCTS

- Axial Flow Fans • Centrifugal Blowers • Kitchen Scrubbers • Ventilation Units
- Air Cooling Units • Dust Collectors • Rotary Airlocks • Air Handling System Accessories

RANGE OF SYSTEMS

- Pressurisation & Ventilation • Evaporative Air Cooling • Dust Extraction & Collection
- Fume Extraction & Collection • Fresh Air Supply & Exhaust • Kitchen Ventilation
- Pneumatic Conveying • Air Conditioning



VENTECH SYSTEMS PVT. LTD.

(An ISO 9001 : 2015 Certified Company)
(Recipient of Bhartiya Udyog Ratna Award)
(Authorized Channel Partners of Hitachi & LG)

Corporate Office: 511, Vikas Deep, Laxmi Nagar District Centre, Vikas Marg, New Delhi – 110 092 (India)

Phone: + 91 – 11 – 22454054 , 22454059 **Mobile:** + 91 97110 03363

Telefax: + 91 – 11 – 42448063 • **E-mail:** info@ventechsystems.com, sales@ventechsystems.com

Branch Office: 410, Angel Mega Mall, CK-1, Kaushambi, Ghaziabad

Works: Ghaziabad & Delhi

Regional Representatives: Lucknow, Raipur, Ahmedabad, Hyderabad, Karnal

Overseas Representatives: Canada, Singapore, South Africa



All Rights reserved. No part of this publication may be copied or published by means of printing, photocopying, microfilm or otherwise without prior written consent of Ventech Systems Pvt. Ltd. This restriction also applies to the corresponding drawings and diagrams.

In view of our constant endeavour to improve the quality of our products & systems, we reserve the right to alter the specifications without prior notice. We reserve the right to modify the specifications in accordance with improved designs. Although every effort will be made to maintain accuracy in the data given, the figures must be taken as approximate and in no way binding. Contact us for more information.

VENTILATION UNITS

Range : 3000 to 50,000 CFM

KITCHEN SCRUBBERS

VENTILATION UNITS

Ventech offers Cabinet fans for supply and exhaust air. The Cabinet fans for supply (Fresh air) are supplied with Pre- filters where as no filters are required to be provided in the Cabinet fans for exhaust air.

SALIENT FEATURES

- Fan : DWDI Centrifugal fan
- Capacity range : 3000 to 50,000 CFM
- Available in both Single / Double skin construction with framework of Aluminium hollow extruded sections.

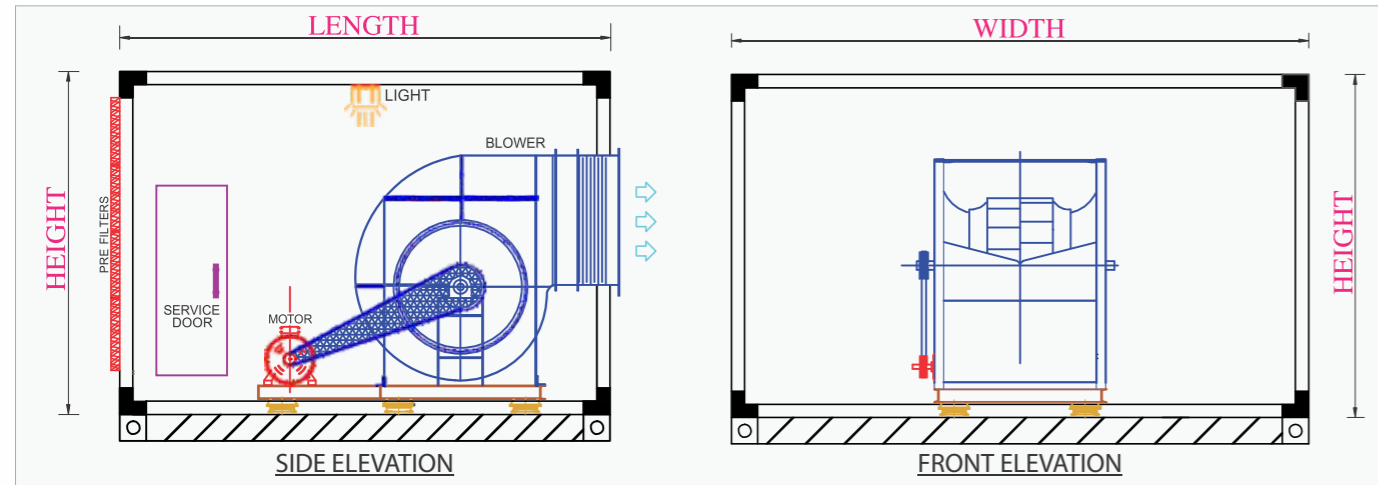

TECHNICAL DATA

Sr. No.	Model	Air Volume (CMH)	Air Volume (CFM)	Dimensions (MM)			Fan Motor(HP) @ 50 mm.WG. Static Pressure
				Length	Width	Height	
1	VEVU-3	5100	3000	1200	1300	1100	2
2	VEVU-4	6800	4000	1200	1300	1100	3
3	VEVU-5	8500	5000	1500	1300	1400	3
4	VEVU-6	10200	6000	1500	1300	1400	5
5	VEVU-7	11900	7000	1600	1300	1400	5
6	VEVU-8	13600	8000	1800	1500	1400	5
7	VEVU-9	15300	9000	1800	1900	1400	7.5
8	VEVU-10	17000	10000	1900	1900	1600	7.5
9	VEVU-12	20400	12000	1900	1900	1600	7.5
10	VEVU-15	25500	15000	2100	1900	2000	10
11	VEVU-18	30600	18000	2300	1900	2200	10
12	VEVU-20	34000	20000	2300	2500	2200	12.5
13	VEVU-22	37400	22000	2500	2500	2200	12.5
14	VEVU-25	42500	25000	2500	3200	2200	15
15	VEVU-28	47600	28000	2700	3200	2200	15
16	VEVU-30	51000	30000	2700	3200	2200	20
17	VEVU-35	59500	35000	2800	3200	3000	20
18	VEVU-40	68000	40000	3100	3200	3000	25
19	VEVU-45	76500	45000	3100	3800	3000	25
20	VEVU-50	85000	50000	3200	4400	3000	30

Note: • Dimensions are indicative only. • All above dimensions are with standard 25 mm thick panels. • Unit base channel height is extra.

KITCHEN SCRUBBERS

“WE PROVIDE YOUR KITCHEN A BREATH OF FRESH AIR”

A Kitchen Scrubber is a smaller and relatively compact size of the Industrial Scrubber especially designed for food industry kitchens, where the volume of pollution is low and limited to particulate matter, oil, odour and mist.

“Ventech” Kitchen scrubbers are customized to scrub kitchen fumes efficiently.



PRINCIPLE OF SCRUBBING



The kitchen fumes are drawn from the kitchen hood through duct and enter the scrubber and flow horizontally. The fumes are scrubbed using opposed spray of high pressure mist created by especially designed nozzles. The water is re-circulated by a pump through sump strainer.

These kitchen scrubbers have SWSI / DWDI centrifugal fans (fan section) installed in the upstream end to draw fumes through the scrubber and letting out relatively clean air.

CAPACITY RANGE : Upto 50,000 CFM

COMPONENTS

- Casing : Single skin / Double Skin in GI construction.
- Blower: Centrifugal backward / forward curved blowers.
- Pump: Monobloc water re-circulating Pump complete with pipe/ pipe fittings including valves/stainers.
- Filters: Washable Aluminium / GI metallic filters.
- Spray headers: GI / PVC / SS Double opposed spray banks.
- Spray nozzles: Brass / PVC.
- Water tank: S.S fabricated / GI / FRP lined.
- Mist Eliminators: PVC / GI 4/6 bend mist eliminators.
- Intake Louvers: GI (to streamline air flow).
- The above scrubber internals can also be installed in the masonry housings with Centrifugal / Axial fans.

ADVANTAGES

- Better work environment
- Odour free environment
- Pollution free emissions

APPLICATIONS

- Food manufacturing Industries
- Hotels/ Restaurants/ Bakeries
- Hospitals/ Canteens